

## The Surelok II

Solid and reliable design. The Surelok II is an industry standard clinching machine.

### Superior features include

- 18" or 25" throat
- Fasten material from 32 gauge up to 14 gauge
- Fast cycle times
- "Intelligent" safety stroke
- Adjustable stroke
- Air powered, requires no electrical hook up
- Upgradeable options

SOLVING METAL FASTENING SOLUTIONS FOR OVER A QUARTER OF A CENTURY



INNOVATIONS IN ENGINEERING

## SPECIFICATIONS - SURELOK II

- Press Design: Solid 3" Steel "C" frame
- Features: WAMP pneumatic power unit  
Air surge tank and regulator  
Foot pedal operated
- Stroke: 1" max. (adjustable)  
Throat: 18" or 25"  
Work Height: 45"
- Upper Tooling: E series Urethane Stripper or  
P Series Steel Stripper  
Adjustable to suit material thickness
- Lower Tooling: Die insert on a 2-piece  
hardened die plate
- Capacity: MAX: Two ply 0.075" mild steel  
MIN: Two ply 0.010" mild steel
- Cycle Speed: 60-80 cycles/ minute (standard)  
Up to 150 cycles/min with HS24V
- Air Requirements: 80psi to 125psi  
125psi (recommended)  
Approx. 5-7cfm (@60-80cpm)  
39-55 scfm@100psi

### Dimensions:

	Surelok18	Surelok25
Width	37"	37"
Length	45"	52.5"
Height	75"	75"
Weight	835 lbsm	1055 lbsm

### Typical Joint Strengths (Mild Steel):

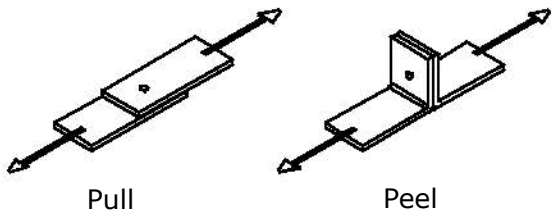

Material Thickness	Pull (lbs)	Peel (lbs)	Die Type
0.075" (14g)	550	225	#50
0.060" (16g)	475	175	#50
0.050" (18g)	430	150	#40/#50
0.040" (20g)	400	120	#40
0.034" (22g)	375	100	#30/#40
0.028" (24g)	325	85	#30
0.022" (26g)	285	70	#30

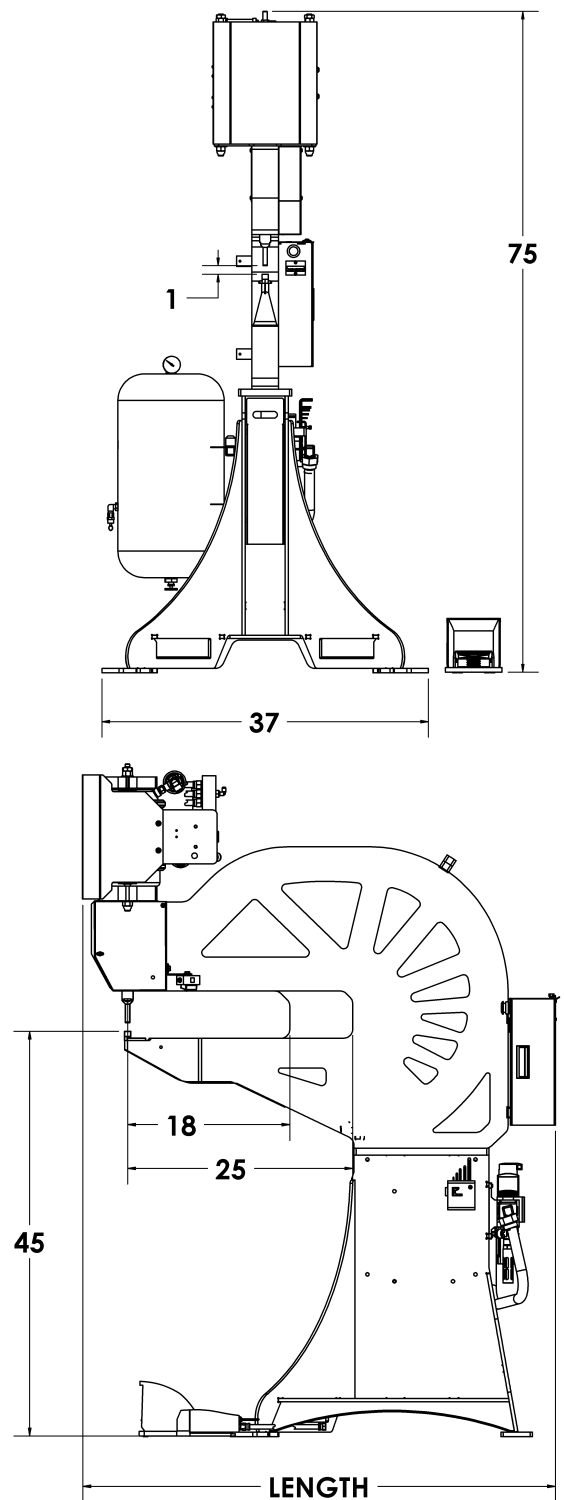

Pipe diameter	Die reach into Pipe
3" Ø	1-3/8"
4" Ø	3 1/4"
5" Ø	5"
6" Ø	12-1/4"
7" Ø	13-5/8"
8" Ø	15-7/8"
9" Ø	18-1/8"
10" Ø	20-1/2" *
11" Ø	22-3/4" *
12" Ø	24-1/2" *

\*Surelok II 25" throat only