



## Letter Lok 4000

Versatile design and unsurpassed features will reduce your channel letter fastening costs.

- 25" throat
- Fast cycle times
- Clinch up to 10" deep letters
- Large table 30" x 60"
- UL recognized tooling\*
- Simple tool adjustment
- Air powered

When you combine all the features, benefits and quality, the Letter Lok 4000 sets the standard for the channel letter industry.

\*Norlok tooling components MP70001, MP70002 & MP70010. This is standard in all Letter Lok 4000 machines

**INNOVATIONS IN ENGINEERING**

*Setting the standards*

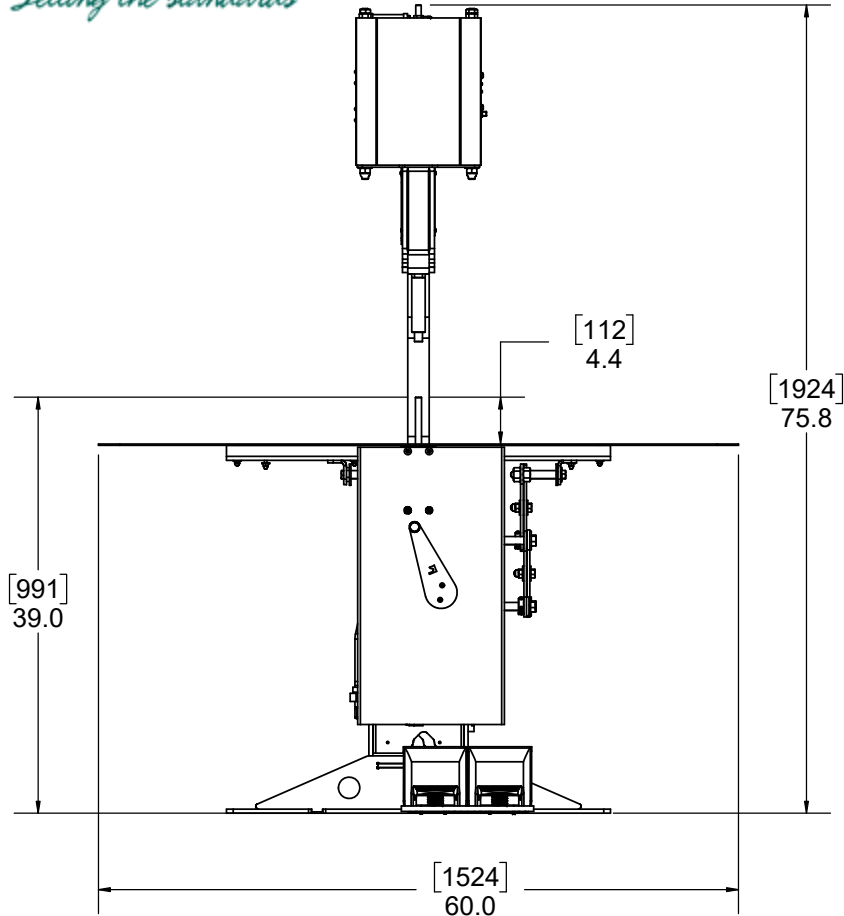

*Lower stem rapidly moves out of the way with the press of the footpedal*

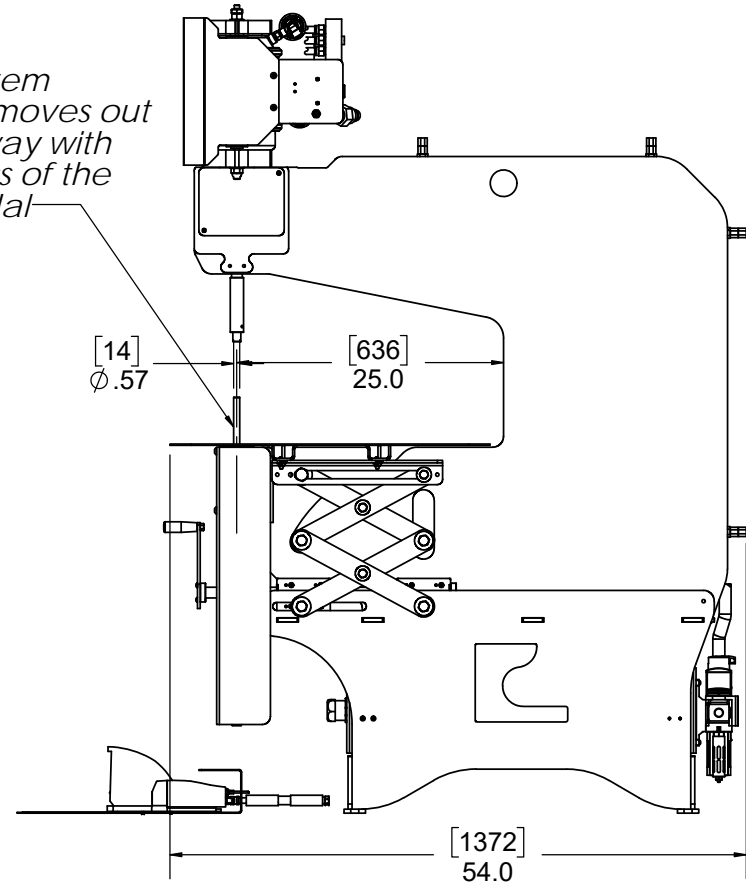

Material	Joined With	Net Max Thickness	Net Min Thickness
Aluminum	Clinch/SPR	0.160" / 4mm *	0.048" / 2.00mm
TPO	SPR	Contact Norlok	
Galvanized Steel	Clinch/SPR	0.120" / 3.8mm *	.030" / 0.50mm
Aluminum Composite	SPR	Contact Norlok	

\* Self Piercing Rivets (SPR) are sold by Norlok. SPR can join thicker material and produce stronger bonds compared to clinch

- Stroke:** 1/4" [6mm] operating  
8" [200mm] low pressure opening
- Throat:** 25" [635mm]
- Max Letter Height:** 8" [200mm] (10" [254mm] option available)
- Table:** 30" deep x 60" wide [760 x 1520 mm]
- Cycle Speed:** 80 CPM
- Air Requirements:** 70-100psi [5-6.8 bar]  
Approx 0.8 cu ft free air per cycle