

Letter Lok 3000 Return Fastener

Designed to fasten the open ends of channel letter returns

- Portable machine
- Air over oil powered clinching machine
- One piece steel frame; 3 ¼" or 4 ½" throat
- UL recognized tooling*
- Fasten up to combined thickness 0.125" aluminum

*Norlok tooling components MP70001 and MP70002

LL3000 Mobile cart

- Optional mobile cart for the Letter Lok 3000 Return Fastener
- 3" diameter locking casters
- Collapsible design for easy shipping and storage
- Mounting location for power unit
- Hooks for machine and hydraulic hoses



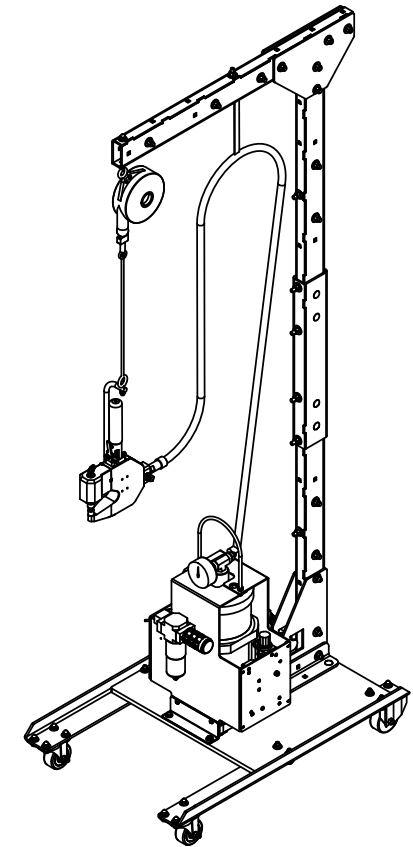
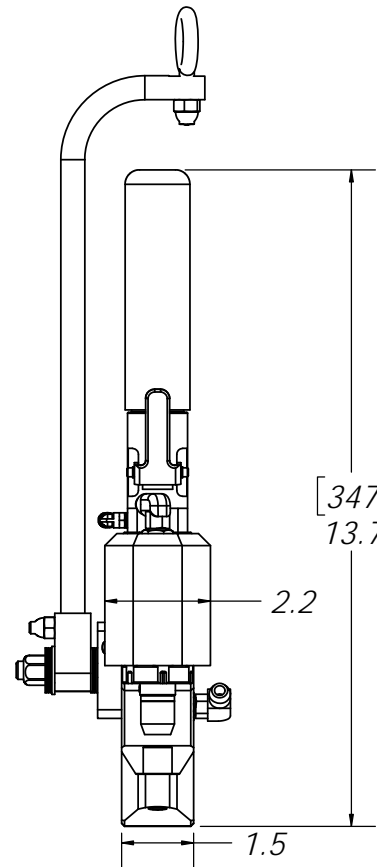
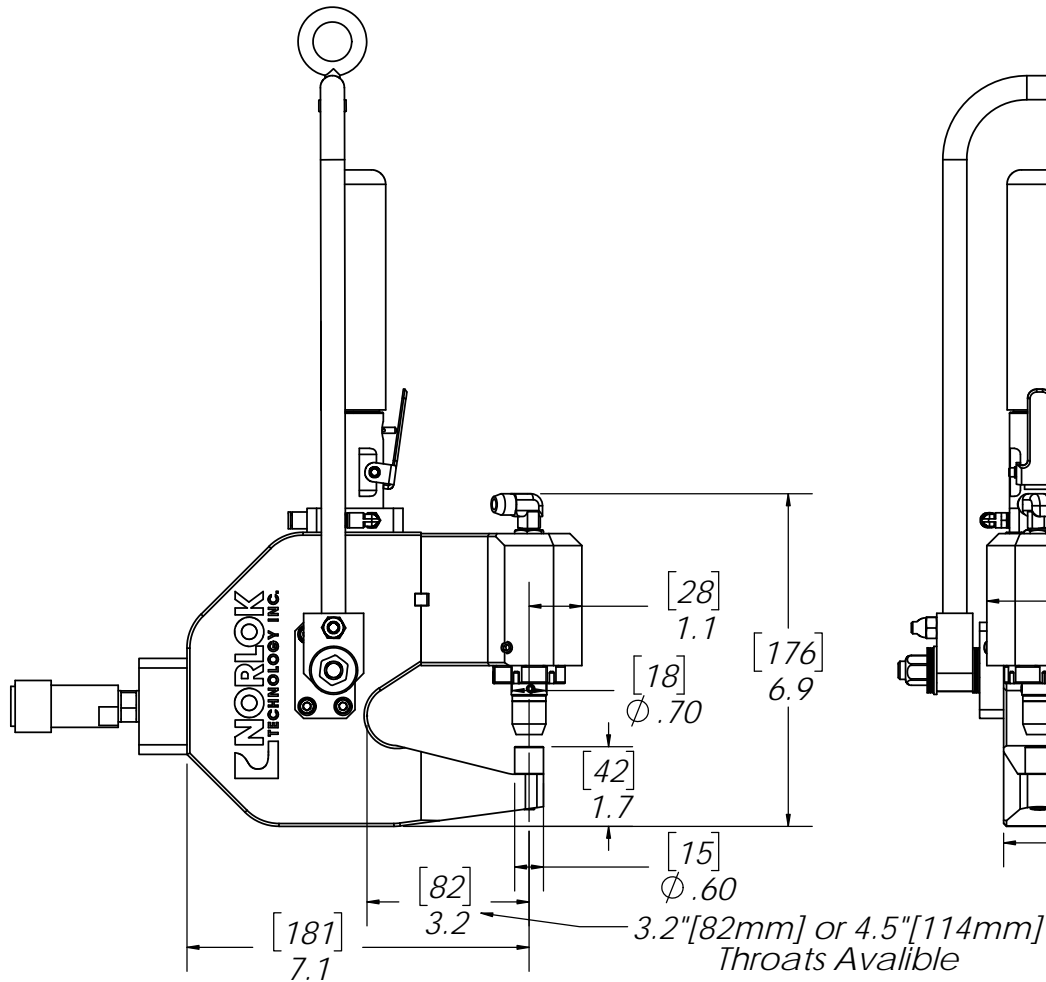

INNOVATIONS IN ENGINEERING

Letter Lok 3000 Return Fastener

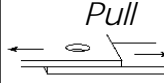

Letterlok 3000 on a Mobile Cart and Spring Balancer

Capacity:	Medium Duty (0.18" diameter punch) MAX: Two ply .063" [1.6mm] mild steel Two ply .063" [1.6mm] prepainted Al. MIN: Two ply .010" [0.25mm] mild steel
Stroke:	1/4" [6mm]
Throat:	3.2" [89mm] or 4.5" [114mm]
Weight:	15 lbs [9.5kg] -hand tool only- 47 lbs [21kg] -power unit-
Cycle Speed:	30-40 CPM
Air Requirements:	70-90psi [5-6 bar] Approx 0.8 cu ft free air per cycle 5HP @ 40 clinches per minute

Options:	Spring Balancer Provides easier machine motion Mobile Hanging Cart 7'[1.8m] tall cart with 2-1/2' [0.75m] arm		
Typical Joint Strengths (Aluminum)			
	Material Thickness (Punch Side/Die Side)	Pull lbs/N	Peel lbs/N
	0.090"/0.063" [2.3/1.6mm]	240/1067	90/400
	0.080"/0.080" [2.0/2.0mm]	265/1178	90/400
	0.063"/0.063" [1.6/1.6mm]	240/1067	72/320
	0.063"/0.040" [1.6/1.0mm]	270/1201	50/222
	0.040"/0.040" [1.0/1.0mm]	175/778	60/266