

The New SURELOK III

11", 18" or 25" Throat Machine

Designed for all clinching applications

With its versatile design and unsurpassed features the Surelok III series of machines outperform the competition like no other.

Solid and reliable, the Surelok III will fasten material from as thick as 14 gauge to as thin as 32 gauge with our proven clinching technology.

Superior Features include...

APU - Advanced Power Unit

- faster, smoother, quieter and uses less air

Rigid steel frame

- less deflection for longer tool life

Close tooling access

- get in close for more applications

Fast cycle times

- for more production

Stainless steel ready

- with a simple punch and die change

11", 18" or 25" throats

- sized to suit your application

"Intelligent" safety stroke

- for greater operator safety

Simple tool adjustments

- little or no setup time

Adjustable 2 1/2" stroke

- convenience of use

Small footprint

- requires less floor space

15 years of design experience

- proven reliability and quality

Air powered

- requires no electrical hookup

When you combine all the features, benefits and quality, the Surelok III sets the standard by which other clinching machines are measured.



SPECIFICATIONS – SURELOK III

- Press Design:** Solid 3" steel "C" frame.
- Features:** APU pneumatic power unit.
Regulator, Shut-off valve
Foot pedal operated
- Stroke:** 2 1/2" max. (adjustable)
- Throat:** 11", 18" or 25"
- Work Height:** 45"
- Upper Tooling:** Round or Rectangular ready
Adjustable to suit material thickness.
- Lower Tooling:**
Die insert on a hardened die plate with
a hardened protection collar.
- Capacity:** MAX: Two ply 0.075" mild steel.
MIN: Two ply 0.010" mild steel.
MAX: Two ply 0.050" Stainless.
MIN: Two ply 0.010" Stainless.
- Cycle speed:** 60-80 cycles/minute (standard)
Up to 150 cycles/minute with options
- Air Requirements:** 80psi to 100psi
100psi (recommended)
Approx. 0.2 cu ft free air per cycle.
(2 HP @ 60 clinches per minute)

Dimensions:

	Surelok18	Surelok25
Width	36"	36"
Length	38"	49"
Height	78"	80"
Weight	940 lbs	1300 lbs

Typical Joint Strengths (Mild Steel):

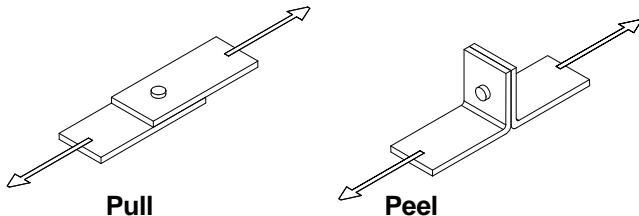

Material Thickness	Pull (lbs)	Peel (lbs)	Die Type
0.075" (14g)	550	225	#50
0.060" (16g)	475	175	#50
0.050" (18g)	430	150	#40/#50
0.040" (20g)	400	120	#40
0.034" (22g)	375	100	#30/#40
0.028" (24g)	325	85	#30
0.022" (26g)	285	70	#30

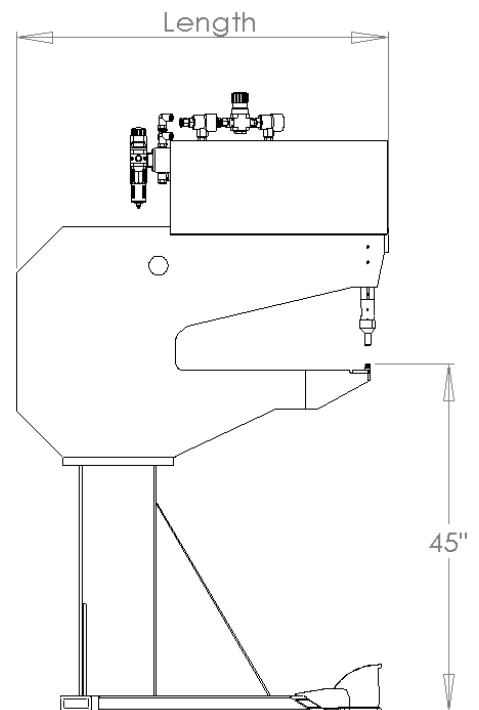
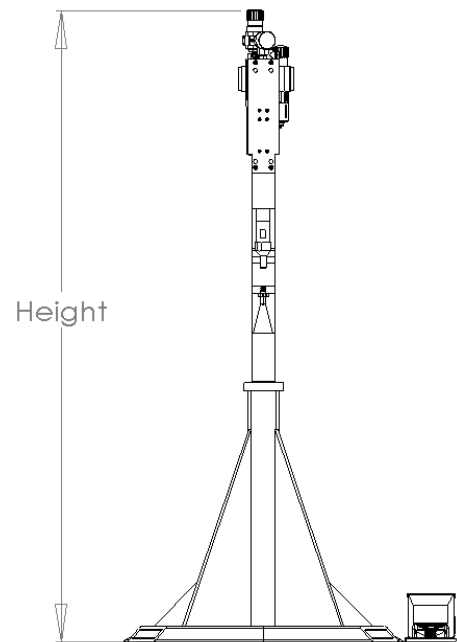

Pipe diameter Die reach into Pipe

3" Ø	1-3/8"
4" Ø	3 1/4"
5" Ø	5"
6" Ø	12-1/4"
7" Ø	13-5/8"
8" Ø	15-7/8"
9" Ø	18-1/8"
10" Ø	20-1/2" *
11" Ø	22-3/4" *
12" Ø	24-1/2" *

*Surelok III 25" throat only